



MTS-500 Semi-Automated Filler and Sealer

Improve Packaging Efficiency in Higher-Volume Operations

Designed to streamline packaging for Correctional and Long Term Care Pharmacies, the MTS-500™ Semi-Automated Filler and Sealer is capable of producing approximately 850 completed single dose medication blister cards per hour.¹ That's up to 34 times faster than packaging by hand, creating greater efficiency for your pharmacy. All settings are preprogrammed, making it simple to operate.

Features

- Motorized medication filling system with adjustable speed and easy-to-change brushes
- Tool-less changeover of the filling system
- Easy-to-read digital temperature controller
- Stainless steel and anodized aluminum construction allows for easy cleaning

Benefits

- Improves labor efficiency through high-speed packaging
- Simplifies packaging of high-volume medications in single dose cards
- Automates pre-pack labeling and barcoding
- Increases flexibility with plate-based filling system



1. Max per hour is one technician filling the same drug without medication changes with optimal conditions.

Specifications

- Height: 66"
- Width: 74-1/4" with printer
- Depth: 86-1/4" with printer
- Weight: 1,200 lbs.
- Electrical: 240 VAC, 1Phase, 20 amps
- Compressed Air: 100 PSI, 15 SCFM
- Adjustable Temperature Range: max. 400°F



MTS-500 front view

Side and Aerial Diagram View

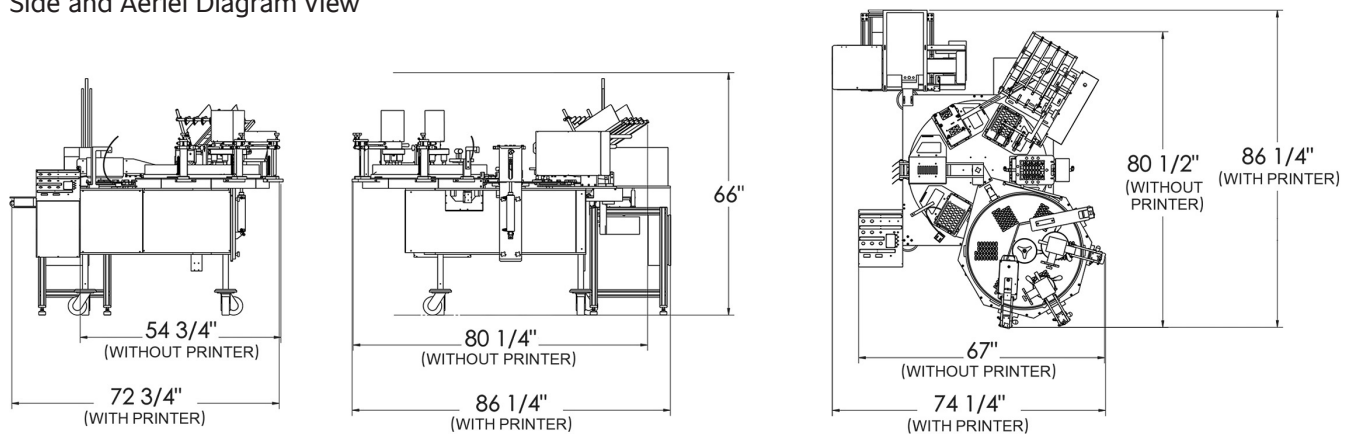

Note: Allow additional 2-foot walkaround each side.

Visit [Omniceil.com/Medication-Adherence](https://www.Omniceil.com/Medication-Adherence) to learn more today.

For Your Pharmacy. For Your Patients.

Your partner for optimized outcomes.

Through industry-leading medication packaging and automation solutions, Omnicell empowers pharmacies to work more efficiently, to improve medication safety and satisfaction for their employees, customers and patients.

